

EXTRACTION OF ANTIOXIDANT FROM SOME BRAZILIAN PLANTS

Priscilla C. Veggi, Diego T. Santos, M. Angela A. Meireles*

LASEFI/DEA/FEA (School of Food Engineering)/UNICAMP (University of Campinas),
Rua Monteiro Lobato, 80; 13083-862, Campinas- SP, Brazil

*E-mail: meireles@fea.unicamp.br & Fax: +551935214027

There are several natural sources of antioxidants. Some of the Brazilian indigenous plants such as jabuticaba (*Myrciaria cauliflora*), *Pyrostegia venusta* (common names: flame vine, flaming trumpet, golden shower), *Heteropterys aphrodisiaca* (nó-de-cachorro), *Inga edulis* (ingá-cipó), *Hymenaea courbaril stilbocarpa* (jatobá) and *Phaseolus vulgaris* L. (beans) are source of natural antioxidants. For instance, jabuticaba is grape-like in appearance and texture, although its skin is thicker and tougher. This fruit has a dark purple to almost black skin color due to its high content of anthocyanins (310-315 mg/ 100 g of fresh weight) that covers a white gelatinous flesh inside. On the other hand, beans (*Phaseolus vulgaris* L.) that are a very important component of Brazilian meal are also an important source of anthocyanins. While, *Pyrostegia venusta* (cipó-de-são-joão), *Heteropterys aphrodisiaca* (nó-de-cachorro), *Inga edulis* (ingá-cipó), *Hymenaea courbaril stilbocarpa* (jatobá) are important sources of flavonoids. In order to evaluate the effectiveness of SFE in obtaining extracts rich in antioxidant the global yields of these plants were determined at 50 °C and 35 MPa. The biological activities of the extracts were determined by measuring the antioxidant activity using the coupled reaction of beta-carotene/ linolenic acid.

Key words: *Heteropterys aphrodisiaca*, *Inga edulis*, *Hymenaea courbaril stilbocarpa*, *Myrciaria cauliflora*, *Phaseolus vulgaris* L., *Pyrostegia venusta*

INTRODUCTION

Extracts of aromatic herbs, spices, and medicinal plants are employed in food processing to impart flavor and other functional properties. Brazil not only has one of the world's highest levels of biodiversity, but also it has an under-used repertoire of plants with potential economic value [1]. However, Brazil has not made satisfactory use of its biodiversity and popular knowledge as regards research and the development of phytotherapeutic agents [2]. Plants have been of crucial importance for human healthcare during several millennia [3]; the extracts of some plants present antioxidant, antiulcerogênica, antimalarial, anticancer and antiinflammatory activities. In particular, the antioxidant activity of plant extracts is mainly attributed to the presence of phenolic compounds, volatile and non-volatile, such as flavonoids, phenolic acids and phenolic diterpenes, thus a selective extraction technique for these compounds is desired.

Jabuticaba (*Myrciaria cauliflora*) is grape-like in appearance and texture, although its skin is thicker and tougher. This fruit has a dark purple to almost black skin color due to a high content of anthocyanins that covers a white gelatinous flesh inside [4]. Some recent papers have demonstrated that the biological (antioxidant, antiradical, etc.) activities of jabuticaba skin extracts are due to their high phenolic compounds content [5].

Pyrostegia venusta is popularly known as cipó-de-são-joão, its leaves and stems are used in traditional medicine as tonic, and to treat diarrhea and dysentery; it is cultivated due to its flashy appearance and reputed therapeutic properties [6]. β -sitosterol, n-hentriacontan,

acacetin-7-O- β -D-glicopyranoside, mesoinositol, stigmasterol, β -amyrin and oleanolic acid were isolated and characterized from their leaves [7-9]. Dos Santos & Blatt [9] also reported a quantitative analysis of flavonoids and total phenolics originating from *Pyrostegia venusta* leaves from the forest and cerrado; the values obtained were 1.72 % and 1.87 % for total phenolics, and 0.62 % and 0.53 % for flavonoids, respectively for the forest and cerrado.

Extracts of *Ingá edulis* Mart. (Leguminosae-Mimosoideae) (Ingá-cipó), have been used in folk medicine as a diuretic and antiinflammatory product [10]. Previous studies of these species showed high values of antioxidant capacity and phenolic content in leaves extract [11]. Flavan-3-ols ((+)-catequin and (-)-epicatequin) and flavonoids (myricetin-3-O- α -L-rhamnopyranoside and quercetin-3-O- α -L-rhamnopyranoside) were the major compounds identified [12]. In study of Souza et al [11], it was verified the occurrence of compounds with significant antioxidant in *I. edulis* leaves that can be used in pharmaceutical and medicinal preparations.

The specie *Heteropterys aphrodisiaca* O. Mach (Nó-de-cachorro) is regarded as a medicinal plant of great importance due to the curative power of its root, including memory and sexual stimulant [13], vasodilatation, physical and physiological invigorating capacities, antiulcerogenic, cleanser and antioxidant properties [14]. Qualitative analysis of the plant extract showed glycosides, polyphenols, tannins, alkaloids, saponins and anthracene derivates as a major compounds [15]. Marques et al. [16] isolated and identified substances of phenolic extract like dihidroflavonoids altilbin, neoastilbin and isoastilbin.

A few examples of biological activities from *Hymenaea courbaril stilbocarpa* (jatobá) extracts have been reported. The Brazilian *H. courbaril* bark provided an extract with high 5-lipoxygenase inhibitory activity; its extract has also been used in the cosmetic industry owing to the polycatechin, which has moisturizing and skin-lightening effects. Flavonoids of varied structures [17] and diterpenes [18] are also common in *Hymenaea* species. Terpenes have various biological activities, such as protection against infections and insect attack [19] and antimicrobial [20].

Finally, common bean (*Phaseolus vulgaris* L.) is well known as a rich source of phytochemicals, such as flavonoids, polyphenols and phenolics, which exhibit natural antioxidant properties [21]. Flavonoids compounds present in the seed coats of beans have been associated to the beans' significant antioxidant activity [22, 23]. Anthocyanins, one class of flavonoids compounds, were detected in the bean coat extract [24]. Tsuda, et al. [25] studied the antioxidation activity of pea bean from ethanol extract prepared from black and read seed coat exhibiting strong antioxidation activity. Nowadays, beans are popular used in disease prevention such as colon cancer, reducing the risk of diabetes, obesity, coronary heart disease [26].

In this context, literature presents several methods to extract antioxidant compounds from these Brazilian plants, however, to our knowledge the use of supercritical fluid extraction (SFE) method for this purpose were not reported. SFE is well known as a clean technology that avoids or minimizes damages to the environment extracting desired compounds by changing the operational conditions. Compared with other techniques as using conventional solvents, products obtained with SFE are free of toxic residues and generally present high quality; in addition, the presence of thermolabile compounds requires the use of techniques at low temperatures to avoid the possibility of hydrolysis, hydrosolubilization, or degradation [27].

For this reason, in this work we evaluated the effectiveness of SFE in obtaining extracts rich in antioxidant from six Brazilian plants. The biological activities of the extracts

were determined by measuring the antioxidant activity using the coupled reaction of beta-carotene/ linolenic acid, comparing with some studies found in literature.

MATERIALS AND METHODS

Raw material preparation

Jabuticaba fruits (*Myrciaria cauliflora*) harvested from a plantation in the State of São Paulo, Brazil, were acquired from a fruit and vegetable market centre (CEASA-Campinas, Brazil). Immediately after acquiring, the fruits were stored in the dark in a domestic freezer (-15 °C) (Double Action, Metalfrio, São Paulo, Brazil) to protect from light to avoid photodegradation. Before extraction, the fruits were manually peeled and the skins were dried at 45 °C until reaching moisture content around 60%.

Leaves of cipó-de-são-joão and Inga-cipó, the root of nó-de-cachorro and bark of jatobá were purchased from Superextra (São Paulo, Brazil); the dried raw materials were backed in plastic bags. They were comminuted in a knife mill (Marconi, model MA 340, Piracicaba, Brazil), packed in plastic bags and stored in a domestic freezer (Double Action, Metalfrio, São Paulo, Brazil) at -15 °C.

The beans (Jalo Precoce cultivar) used in this work were donated from Embrapa Arroz e Feijão (State of Goiás, Brazil). For this study, it was utilized ground bean, that was comminuted in a knife mill (Marconi, model MA 340, Piracicaba, Brazil), packed in plastic bags and stored in a domestic freezer (Double Action, Metalfrio, São Paulo, Brazil) at -15 °C.

Experimental Procedure

The total amount of soluble material or global yield (X_0) at a given temperature and pressure was determined using Spe-ed SFE system (Applied Separations, Allentown, USA) equipped with a 6.57 cm³ extraction cell (Thar Designs, Pittsburg, USA). The column was filled with raw material. The temperature and pressures selected for the extraction were 50 °C and 35 MPa. Carbon dioxide (99.5% purity, Gama Gases Especiais, São Paulo, Brazil) was admitted into the system keeping the flow rate fixed in 5.5×10^{-5} kg/s fixing the relation S/F (ratio between the mass of solid and solvent) constant and equal to 50. The total amount of CO₂-soluble material was calculated as the ratio of the total mass of extract and the total initial mass of raw material (wet basis); the assays were carried out in duplicated.

Figure 1 is a simplified representation of the equipment used to determine the global yield. A thermostatic bath (TB) adjusted at -10°C guarantee that the CO₂ is liquid before entering the pump. The pressurization system is formed by a pneumatic pump (PP) where the CO₂ is compressed to the extracting pressure. Then, the solvent flows into a fixed-bed of formed with the raw material (BE) installed inside an oven with electric heating. The process temperature is controlled by a thermocouple on outer wall of the extractor, and its temperature is considered to be the same to the interior of extractor. The extract is collected after the micrometric expansion valve (V4) in a separator (S), a glass bottle of 50 cm³ at ambient pressure which acts as a flash separator, at predetermined intervals time. After passing trough the flowmeter (FM), the solvent passes through a flow totalizer and is then released to the environment.

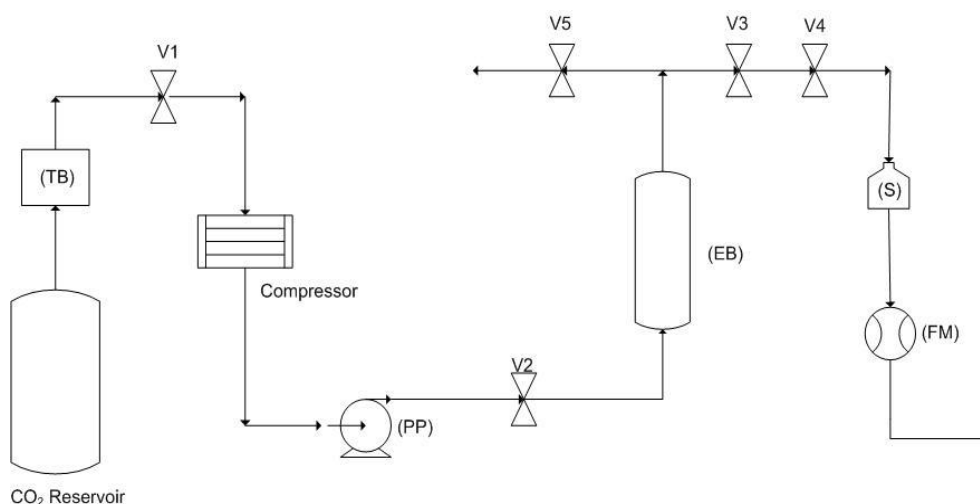

Figure1: Simplified representation of the extraction unit.

Extract Characterization

Antioxidant Activity (AA)

The evaluation of antioxidant activity of the extracts was based on coupled oxidation of β -carotene and linoleic acid. The technique developed by Marco [28] consisted of measuring the bleaching of β -carotene resulting from oxidation by degradation products of linoleic acid. One milligram of β -carotene (97 %, Sigma-Aldrich, St. Louis, USA) was dissolved in 10 cm³ chloroform (99 %, Ecibra, Santo Amaro, Brazil). The absorbance was tested after adding 0.2 cm³ of the solution to 5 cm³ of chloroform, then reading the absorbance of this solution at 470 nm using a UV–Vis spectrophotometer (Hitachi, model U-3010, Tokyo, Japan). A reading between 0.6 and 0.9 indicated a workable concentration of β -carotene. One milliliter of β -carotene chloroform solution was added to a flask that containing 20 mg of linoleic acid (99 %, Sigma-Aldrich, St. Louis, USA) and 200 mg Tween 40 (99%, Sigma-Aldrich, St. Louis, USA). Chloroform was removed using a rotary evaporator (Laborota, model 4001, Viertrieb, Germany), with vacuum control (Heidolph Instruments GmbH, Viertrieb, Germany) and thermostatic bath at 40 °C; then 50 cm³ of oxygenated distilled water (oxygenation for 30 minutes) was added to the flask with vigorous agitation to form an emulsion. Five milliliter of the emulsion was added to 0.2 cm³ of the antioxidant solution (7.5 mg of extract/1 cm³ of ethanol) in assay tubes; (to the control solution 0.2 cm³ of ethanol was added). A blank consisting of 20 mg linoleic acid, 200 mg Tween 40 and 50 cm³ oxygenated distilled water was used to bring the spectrophotometer to zero. Tubes were manually shaken and absorbance measurements made at 470 nm immediately after the addition of the emulsion to the antioxidant solution. The tubes were placed in an water bath (model TE 159, Tecnal, Piracicaba, Brazil) at 50 °C. Absorbance measurements were made at 30 minutes intervals during 3 hours. The antioxidant activities (AAs) were calculated by equation (1) [29]:

$$AA(\%) = 100X \left(1 - \frac{Abs_{extract}^{t=0} - Abs_{extract}^t}{Abs_{control}^{t=0} - Abs_{control}^t} \right) \quad (1)$$

Statistical Analysis

For establishing the statistical significant differences or similarities between the values of antioxidant activities (%), the Tukey's test was used. A confidence coefficient of 95 % was used for the comparison of all the mean's pairs.

RESULTS

Figure 2 shows the SFE global yields (X_0) obtained for the six Brazilian plants at 50 °C and 35 MPa.

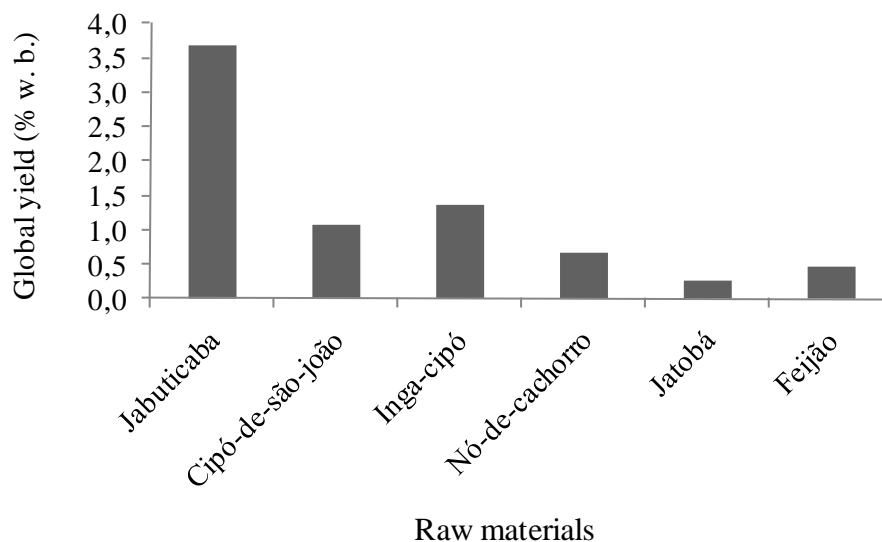

Figure 2: SFE Global yields (X_0) (mass of extract/mass of raw materials)

It can be observed that jatobá presents the smallest global yield ($X_0 = 0.25\%$, w.b.). On the other hand, jabuticaba presented the largest yield ($X_0 = 3.68\%$, w.b.). These results are directly associated to the solubility of each plant extract in supercritical CO_2 . Then, in other words the extract with highest solubility in supercritical carbon dioxide at the studied conditions was the jabuticaba extract followed by Inga-cipó, Cipó-de-são-joão, Nó-de-cachorro, Feijão and Jatobá extracts.

The fixed operational condition of temperature and pressure selected for extraction had the purpose to evaluate the potentiality of pure supercritical carbon dioxide to extract antioxidant compounds of these six plants since to our knowledge there is no data in literature until now. According to our experience, in general, supercritical CO_2 at moderate temperature (around 50 °C) and high pressure (around 35MPa) due to its high density, as extraction solvent can promote the solubilization of different compounds usually found in SFE extracts. Nevertheless, the solubility behavior of each specific compound present in the extract may not be the same [30]. Thus, further experiments in order to evaluate the effect of operational conditions in the composition of the extract are necessary and will be done.

Knowing that all selected plants are characterized by the presence of phenolic compounds, specifically, anthocyanins one class of flavonoid compounds and diverse others flavonoid compounds, and that they are related to the antioxidant activity of the plants, the antioxidant activity of each extract were evaluated (Table 2).

The pure standards' antioxidant activity (BHT and Quercetin) presented higher values than the reported for the extracts, as expected. Comparing the results of the plant extracts with

the standards it is verified the potential of some SFE plant extract as a source of natural antioxidants. Beans extract showed the highest antioxidant activity followed by Cipó-de-são-joão and Inga-cipó (statistically the same value) and Nó-de-cachorro.

According to the method employed (using the coupled reaction of beta-carotene/linolenic acid) to measure the antioxidant activity the Jabuticaba and Jatobá extracts did not show antioxidant activity. Possibly, at the operational condition evaluated no antioxidant compounds were extracted from these raw materials or the method employed was not suitable. Lanfer-Marquez et al. [31] have demonstrated that β -carotene bleaching method was not suitable to measure antioxidant activity of some types of extracts. To verify that, other methods for measuring antioxidant activity will be used in the future.

Table 2: Antioxidant Activities of SFE extracts

Plants	AA (%) After 1 h of reaction	AA (%) After 2 h of reaction
BHT	99.43	96.89
Quercitin	83.70	80.58
Jabuticaba	3.05	-1.23
Cipó-de-são-joão	42.47	31.22
Inga-cipó	40.93	31.69
Nó-de-cachorro	42.14	26.52
Jatobá	2.80	-0.34
Beans	65.79	48.13

As mentioned before, there is no data involving the evaluation of the effectiveness of SFE in obtaining extracts from these six plants with antioxidant activities. Otherwise, extracts obtained, mainly, by conventional solvent extraction techniques from these Brazilian plants were investigated using different solvents (methanol, ethanol, water, etc) and using different antioxidant activity method (DPPH, ORAC, TRAP, TEAC, etc). Normally, these studies have focused on the quantitative analysis of flavonoid, flavonol and phenolic compounds content and their possible correlation to the antioxidant activity [9, 11, 12, 16, 32].

CONCLUSION

The potential of some Brazilian plant extract obtained using pure supercritical carbon dioxide as a source of natural antioxidants were investigated.

The extract with highest solubility in supercritical carbon dioxide (highest X_0) at the studied conditions (50 °C and 35 Mpa) was the jabuticaba extract followed by Inga-Cipó, Cipó-de-são-joão, Nó-de-cachorro, Beans and Jatobá extracts.

Beans extract showed the highest antioxidant activity followed by Cipó-de-são-joão and Inga-cipó (statistically the same value) and Nó-de-cachorro. Jabuticaba and Jatobá extracts did not show antioxidant activity possibly due to at the operational condition used no antioxidant compounds have been extracted or the method employed (β -carotene bleaching method) was not suitable.

ACKNOWLEDGMENTS

The authors are grateful to CNPq (580401/2008-1) and FAPESP (2008/10986-2) for the doctorate fellowships and for the financial support. We also thank EMBRAPA for the sample of beans used in this work.

REFERENCES

- [1] ALBUQUERQUE, U. P., MEDEIROS, P. M., ALMEIDA, A. L. S., MONTEIRO, J. M., NETO, EMFL., MELO, JG., SANTOS, JP., *Journal of Ethnopharmacology*, Vol. 114, **2007**, p. 325.
- [2] CALIXTO, J. B., *Journal of Ethnopharmacology*, Vol. 100, **2005**, p. 131.
- [3] BALBANI, A. P. S., SILVA, D. H. S., MONTOVANI, J. C., *Expert opinion on Therapeutic Patents*, Vol. 19 (4), **2009**, p. 461.
- [4] TERCI, D. B. L., Thesis, Institute of chemistry, University of Campinas, Campinas, Brazil. **2004**.
- [5] REYNERTSON, K. A., YANG, H., JIANG, B., BASILE, M. J., KENNELLY, E. J., *Food Chemistry*, Vol. 109 (4), **2008**, p. 883.
- [6] DUARTE, M. R., JURGENSEN, I. *Latim American Journal Pharmacy*, Vol. 26 (1), **2007**, p. 70.
- [7] FERREIRA, D. T., ÁLVARES, P. S. M., HOUGHTON, P. J., BRAZ-FILHO, R., *Química nova*, Vol. 21 (1), **2000**, p. 42.
- [8] VIVEK, K., SHARMA, S., PAREEK, R. B., SINGH, P., *Journal of the Indian Chemical Society*, Vol. 79 (6), **2002**, p. 550.
- [9] DOS SANTOS, M. D., BLATT, C. T. T., *Revista Brasileira de Botânica*, Vol. 21 (2), 1998, p. 135.
- [10] SILVA, E. M., ROGEZ, H., LARONDELLE, Y., *Separation and Purification Technology*, Vol. 55, **2007**, p. 381.
- [11] SOUZA, J. N. S., SILVA, E.M., LOIR, A., REES, J. F., ROGEZ, H., LARONDELLE, Y., *Food Chemistry*, Vol. 106, **2008**, p. 331.
- [12] SOUZA, J. N. S., SILVA, E. M., SILVA, M. N., ARRUDA, M. S. P., LARONDELLE, Y., ROGEZ, H., *Journal of Brazilian Chemical Society*, Vol. 18 (6), **2007**, p. 1276.
- [13] GALVÃO, S. M. P., MARQUES, L. C., OLIVEIRA, M. G. M., CARLINI, G. A., *Journal of Ethnopharmacology*, Vol. 79, **2002**, p. 305.
- [14] POTT, A., POTT, V. J., *Plantas do Pantanal*, EMBRAPA-SPI, Corumbá, 1994, p. 101.
- [15] GALVÃO, S. M. P., **1997**. MsS thesis, Federal Univesity of São Paulo, São Paulo.
- [16] MARQUES, L. C., DE PIERI, C., ROMAN-JUNIOR, W. A., CARDOSO, M. L. C., MILANEZE-GUITIERRE, M. A., MELLO, J. C. P., *Revista Brasileira de Farmacognosia*, Vol. 17, **2007**, p. 604.
- [17] PETTIT, G. R., MENG, Y., STEVENSON, C. A., DOUBEK, D. L., KNIGHT, J. C., CICHACZ, Z., PETTIT, R. K., CHAPUIS, J., SCHMIDT, J. M., *Journal of natural products*, Vol. 66, **2003**, p. 259.
- [18] NOGUEIRA, R. T., SHEPHERD, G. J, LAVERDE, J. R. A, MARSAIOLI, A. J, IAMAMURA, P. M., *Phytochemistry*, Vol. 58, **2001**, p. 1153.
- [19] ROBBERS, J. E, SPEEDIE, M. K, TYLER, V. E., *Farmacognosia e Farmacobiocnologia*. Williams & Wilkins. Baltimore, MA - USA, **1997**.
- [20] FERNANDES, T. T., SANTOS, A. T. F., PIMENTA, F. C., *Revista de Patologia Tropical*, Vol. 34(2), **2005**, p. 113.
- [21] SUTIVISEDSEK, N., CHENG, H. N., WILLET, J. L., LESCH, W. C., TANGSRUD, R. R., BISWAS, A., *Food Research International*, Vol. 43, **2010**, p. 516.
- [22] RANILLA, L. G., GENOVESE, M. I., LAJOLO, F. M., *Journal of Agricultural and Food Chemistry*, Vol. 57, **2009**, p. 5734.
- [23] BENINGER, C. W., HOSFIELD, G., *Journal of Agricultural and Food Chemistry*, Vol. 51, **2003**, p. 7879.

- [24] TAKEOKA, G. R., DAO, L. T., FULL, G. H., WONG, R. Y., HARDEN, L. A., EDWARDS, R. H., BERRIOS, J. J., *Journal of Agricultural and Food Chemistry*, Vol. 45, **1997**, p. 3395.
- [25] TSUDA, T., OHSHIMA, K., KAWAKISHI, S., OSAWA, T., *Journal of Agricultural and Food Chemistry*, Vol. 42, **1994**, p. 248.
- [26] ROSS, K. A., BETA, T., ARNTFIELD, S. D., *Food Chemistry*, Vol. 113, **2009**, p. 336.
- [27] PEREIRA, C. G., MEIRELES, M. A. A., *Flavour and Fragrance Journal*, Vol. 22, **2007**, p. 407.
- [28] MARCO, G. J., *Journal of the American Oil Chemist's Society*, Vol.45, **1968**, p.594.
- [29] BURDA, S., OLESZEK, W., *Journal of Agricultural and Food Chemistry*, Vol. 49, **2001**, p. 2774.
- [30] SALDAÑA, M. D. A., MOHAMED, R. S., BAER, M. G., MAZZAFERA, P., *Journal of Agricultural and Food Chemistry*, Vol. 47, **1999**, p. 3804.
- [31] LANFER-MARQUEZ, U. M., Barros, R. M. C., SINNECKER, P., *Food Research International*, Vol. 8-9, **2005**, p. 885.
- [32] SUZUKI, R., MATSUSHITA, Y., IMAI, T., SAKURAI, M., JESUS, J. M. H., OZAKI, S. K., FINGER, Z., FUKUSHIMA, K., *Journal of Wood Science*, Vol. 54, **2007**, p. 174.